

# The Smart Way to Bend

## Aluminium Arched Frames



- ◆ **2 Week turnaround**  
on all standard colours
- ◆ **Nationwide delivery**
- ◆ **Continuous curve**  
long leg bend
- ◆ **Pregasketed profile**  
with a clip in bend
- ◆ **Slim profile**
- ◆ **A- Energy rating**  
with standard double glazed units

# The window and door system for the future

ecoenergy<sup>PLUS</sup>

# Zero|90

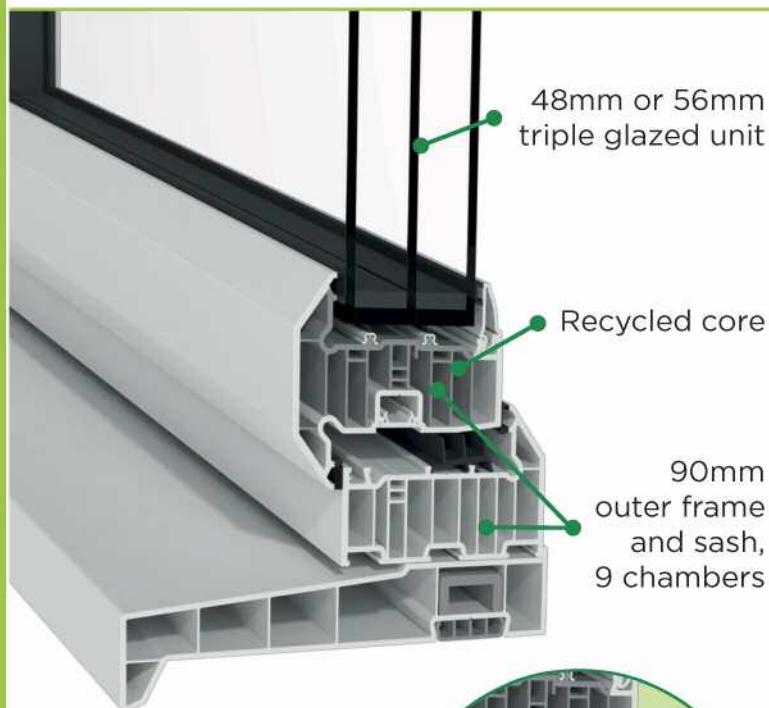

70mm to 90mm "retro-fit" frame option - ideal for replacement market

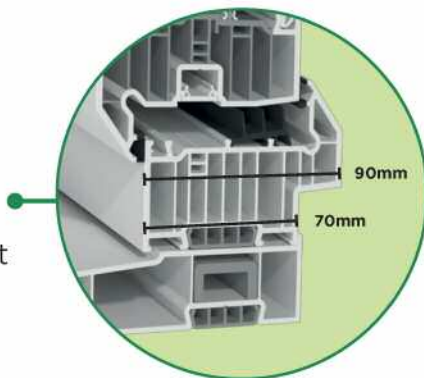

## ENERGY SAVING

U-Values as low as 0.66 W/msK



## NOISE REDUCING

Can reduce noise levels by up to 42 decibels - halving the sound transmission of a standard PVCu window



## SUSTAINABLE CHOICE

Replacing a standard PVCu window with **Zero|90** containing recycled components offers the equivalent carbon saving of planting over 700 more trees

## Now available as a full range of products

Casement windows, tilt and turns, single and double doors



### INNOVATIVE

Including the UK's first Passivhaus certified PVCu window, the **Zero|90** system is ideal for Future Homes and buildings.



### CONTEMPORARY

With a modern, chamfered design, **Zero|90** is available in a choice of popular coloured foiled finishes to suit every building.



### ATTRACTIVE

Despite its 90mm depth, a **Zero|90** window has the same slim, symmetrical sightlines as a standard Liniar 70mm window.



### SAFE AND SECURE

All **Zero|90** products are fully tested and compatible with British Standard PAS24 and Secured By Design, meeting Part Q building regulations.

For more information contact our Sales Director Stuart Bull on 07789 692340  
Phone: 01268 285544 • Fax: 01268 284433 • E-mail: [stuart@sgmwindows.co.uk](mailto:stuart@sgmwindows.co.uk)  
Honywood Square, Honywood Road, Basildon, Essex SS14 3HT

[www.sgmwindows.co.uk](http://www.sgmwindows.co.uk)

**SGM**  
WINDOW MANUFACTURING LTD

# ring ring

You might think that emails or social media messages have surpassed the good old phone call, but according to [businesswire.com](https://www.businesswire.com), 52% of respondents said the phone is their primary communication tool. The importance of this might sometimes be overlooked.

The humble telephone call remains a vital tool for customer engagement, relationship building, and business growth. Here, we delve into why promptly answering calls is crucial for businesses.

At the heart of the matter lies customer satisfaction, because essentially when customers reach out to a business via phone, they are seeking information, assistance, or perhaps even making a purchase. Failing to answer their calls promptly can lead to frustration and dissatisfaction, tarnishing the company's reputation and potentially driving customers away to competitors who are more responsive.

Unanswered calls simply represent missed opportunities. Each call is a potential lead or sale waiting to be captured and by neglecting to answer calls, businesses risk losing out on valuable prospects and revenue. Just one missed call each week equals 52 lost sales opportunities every year. Those numbers can soar when you take

into account the missed calls that may have led to repeat, loyal customers who refer your business to others.

To measure the impact of missed calls, businesses can track their call abandonment rate. This metric reflects the percentage of callers who hang up before reaching a representative or leaving a message. A call abandonment rate exceeding a certain threshold indicates a problem with call handling that requires attention. In the famous words of Peter Drucker: "If you can't measure it, you can't manage it." And if you can't manage it, how will you ever be able to improve it?

For example, a threshold of 5% call abandonment rate could be set as a benchmark. If the call abandonment rate consistently exceeds this threshold, it signals a need for action. Businesses can then implement strategies to improve call handling and reduce these missed opportunities.

Implementing call forwarding or automated call routing systems is one technique you could use to help ensure that calls are directed to the appropriate department or individual without delay.

Another effective strategy would be to enlist the services of a professional receptionist or virtual receptionist service. These services ensure that every call is promptly answered regardless of the time of day or the availability of in-house staff. And with outsourcing call handling to experts, businesses can provide a seamless and professional experience for callers while freeing up internal resources to focus on core tasks.

## contact

01675 481920  
[press@visionpublications.co.uk](mailto:press@visionpublications.co.uk)  
[@vision\\_mags](https://twitter.com/vision_mags)

our readers **3,077**

- 2,121 ■ installers & builders
- 763 ■ manufacturers
- 319 ■ suppliers
- 129 ■ glass merchants & processors
- 155 ■ igu manufacturers
- 44 ■ local authority & housing associations



June issue deadline  
 23<sup>rd</sup> May @5pm

The views expressed by contributors in Vision are not necessarily those of the publisher and Vision Publications take no responsibility for any errors. The publisher also accepts no responsibility for the advertising content, including any error, omission or inaccuracy. Vision Publications retains the right to re-publish any images or information sent to the publication.

However, where phone calls are being answered, sometimes a "no names" policy is often employed to shield sales and marketing teams from perceived unsolicited cold calls. But beneath its surface simplicity, lie several potential pitfalls, that may undermine its efficacy and ultimately harm the organization.

Primarily among these drawbacks is, once again, the risk of missed opportunities. By erecting barriers that prevent perceived cold callers from reaching the appropriate departments, companies may inadvertently shut the door on valuable prospects or partnerships with genuine inquiries from interested parties dismissed.

On top of that, this policy can tarnish the customer experience. From the

perspective of potential business prospects, being rebuffed by a receptionist without ever reaching their intended destination can breed frustration and dissatisfaction. Such interactions leave callers feeling unheard and undervalued, potentially souring their perception of the company and dissuading future engagement.

The bottom line is that answering calls promptly and efficiently is essential for businesses to maintain customer satisfaction, capture valuable leads, and drive revenue growth. By tracking call abandonment rates, setting thresholds for action, and implementing strategies to mitigate missed opportunities, businesses can ensure that they are maximizing the potential of every incoming call.

## GIVE YOUR PROJECTS THE EDGE

edgebp.co.uk | 0330 191 1982 | sales@edgebp.co.uk

Order by 3pm for **next day delivery** (South East Only)



**WINDOW FINISHING**



**SEALANTS & FIXINGS**



**CLADDING**



**FASCIAS & SOFFITS**



**TRIM SPRAYING**

# face-to-face is best

balls2marketing.co.uk

Sarah Ball, Joint MD at Balls2 Marketing and 'Chief PiG' at the People in Glazing Society (PiGs), explains the importance of meeting face-to-face.

When the Covid pandemic pretty much stopped the world in its tracks four years ago, and nearly everyone was made to work from home, one thing a lot of people said they missed was being able to have a conversation face-to-face.

It is for sure something we took for granted. Something so small, but so meaningful. Yes, apps like Zoom, and subsequently Teams to name a couple, gave us a way of creating a means to an end by having virtual meetings, catchups etc.

And now, although the team at Balls2 Marketing work from the office, they still use Teams for that instant messaging both in the office and even more when they are out on the road or in a meeting for example.

But there is absolutely no denying that speaking to someone in person is just what us humans were meant to do.

This is backed up by our first PiGs networking event of the year that took place in Birmingham recently.

Yes, we are four years on from the pandemic, but the appetite for in-person networking and socialising is obviously still so strong within our industry.

We had a record turnout for the event, with an all-time high of 186 pre-registrations for the event. But in fact, we had over 200 in attendance, all there to meet up with friends, colleagues, customers, or the chance to link up with potential new clients and fellow industry professionals.

The chance to just have an informal chat with industry peers, over a few drinks, is something that I think we probably took for granted prior to 2020.

But not now. These type of meetings, and more formal meetings and conferences like the FIT Show, Glazing Summit and the like, are all prime examples of why face-to-face is best.

I'm sure there's much research that has been done about being able to read body language, and not having to say: "you're on mute", but in a relaxed environment, I believe enjoying a person's company is how it is meant to be.

And on that note, we hope we can see many faces new and old at our next networking event in Bristol on 13 June. Your industry colleagues will be there, will you?

For more information contact sarah@balls2marketing.co.uk or call 07540 049655.



**Balls<sup>2</sup>**  
Marketing

Sarah Ball  
Joint MD



## veka unveils omnia: the next generation of fenestration

**One suite of double-rebated and double-flush extrusions for every application, that's fit for the future and easy to produce and install – OMNIA introduces a brand-new era for fenestration.**

Designed and developed in close collaboration with its customers and partners, the launch of Omnia signals the next generation of fenestration, encompassing the needs of the whole industry and end users.

VEKA says that Omnia is no ordinary profile system. It's a pioneering new suite of extrusions for double flush windows and doors that offers homeowners a complete flush look across all their windows and doors, retaining authentic detailing inside and outside the house, from just one suite of profiles.

As a double-rebated, double-flush system it offers a range of possibilities across casement windows and tilt and turn, plus residential doors and French doors – meeting the highest energy, weather, and acoustic performance standards.

The collaborative design and development process, which has taken place over four years, has enabled Veka to completely revolutionise the

fabrication and installation process through working closely with its partners to create something that the industry truly needs and is excited for.

Omnia's co-extruded PCE gasket and cost-effective mechanical jointing techniques streamline production and its future-proof 70mm depth makes the practicalities of placement and removal simple.

The UK precision engineered suite also exceeds energy efficiency requirements set for 2025 building regulations, making it beneficial for reducing the energy cost of homeowners, and its subtle shadow line will offer the high-quality and highly desirable aesthetic appeal customers are looking for.

The man behind Omnia is Veka's Design and Development Manager, Phil Gregory, who said: "It's incredible to finally introduce Omnia to the world after four years of development. The reaction has been amazing so far.

"We've built more than five decades of market-leading experience and expertise into Omnia and it is the right design at the right time. There are so many reasons to choose Omnia." Neil Evans, Managing Director, described Omnia as a game-changer, saying: "Veka is renowned for market-leading designs, and this suite is exactly that. Omnia captures the essence of Veka, with the product incorporating the kind of innovative vision, with a sustainable and collaborative legacy, that has defined our company for generations."

Omnia was first showcased at last month's Veka partner event in Burnley and at the Fensterbau Frontale event in Nuremberg, Germany, and Veka's customers have been hugely complimentary of the new suite.

Simon Holt of Consort Ltd said: "Omnia is great because it's a first – nobody else has done it. That's the biggest thing. It's different. And I want to be first as a fabricator."

With his colleague, Andy Miller adding: "It's a fabulous product. Classy. No compromise."

Andy Jones of New World Developments Ltd said: "It's exactly where the market needs to be. The only flush system designed from scratch. A complete system."

And Roy Frost of Listers Central Ltd praised the product for being in the 'sweet spot.' He said: "We make 3,000 windows a week across different sectors so, for us, this new product is absolutely in the sweet spot. Modern design, nice gaskets, double rebated – lovely. We like it."

Veka plc is a leader in the design, development, and extrusion of PVCu door, window, and conservatory systems. Demonstrating engineering excellence for over 50 years, it employs more than 400 people from its UK manufacturing facility based in Burnley, Lancashire.



# The UK's Leading Trade Fabricator for...

Classic Heritage Doors

1.4

U-value

with Double Glazing

Single or French options

*Where Quality is  
a Way of Life*

call 01793 530808 fax 01793 614600  
email [sales@gardenofeden.co.uk](mailto:sales@gardenofeden.co.uk) online [www.gardenofeden.co.uk](http://www.gardenofeden.co.uk)



# Discover next-level welding technology that delivers a perfect seamless weld every time

As the UK's exclusive supply partner of Graf Synergy machines, Haffner delivers the seamless weld machine innovation to take your business to the next level.

Seamless Welding Technology



- Superior transom welding quality
- V-Perfect® transom welding technology
- Weld seam elimination
- Suitable for both V Joints and Butt Joints
- Precision accuracy - delivering a perfect weld every time
- Faster, automated fabrication



*Discover more of the benefits of Graf Synergy machines from Haffner*

Tel 01785 222421  
[www.haffnerltd.com](http://www.haffnerltd.com)



# new woodgrain foiling service

sheerline.com

Sheerline has announced the launch of a new woodgrain foiling service that introduces an authentic wood effect option across the company's entire aluminium range of windows and doors, including the popular Prestige Lift & Slide Patio Door and Prestige Bi-folds.

It's the ideal option for homeowners who already have wooden or wood-style frames and want a perfectly matched product that offers the hard-wearing, high-security, and slim profile offered by aluminium, but with a wooden aesthetic.

Partnering with the industry leading supplier of laminated foils, Renolit, Sheerline is offering eight foils from stock, covering the most commonly used colours. All produced at Sheerline's vertically integrated manufacturing site - customers can have the best of both worlds. Capturing the 'Scandi look' inside, and combining it with a hard wearing, low maintenance architectural aesthetic for the exterior.

Available in just 10-days from order for fabricator customers, this agile service is yet another way that Sheerline is raising the bar in the world of aluminium. Dual colours and combinations with powder coated finishes are also offered in the same timescale.

A full range of bespoke foils are also available on a slightly extended 15-day lead-time. Ideal for customers looking to differentiate their offering, or to meet an exacting client's vision for their home.



The new service has been launched in time for Spring/Summer 24 to reach homeowners who are planning renovations for 2024. The company appreciates the fact that upgrading existing windows and doors is often the quickest ways to change the overall look of a home.

Ross Hartshorn, Technical Production Director, commented: "We recognise the fact that Scandi and wood-effect styling have grown in popularity over the

past few years, both from an aesthetic and lifestyle perspective. We want to help homeowners achieve their dream home style while keeping things straightforward for fabricators and installers."

"The latest innovation from Sheerline very much reflects our ethos of increasing customer choice, but without compromising on the things that are important; in-built security, warm cosy homes, a stylish aesthetic, and sustainability," they added.

**smart**  
architectural aluminium

# MANUFACTURER

- The Professional's Choice -  
heritage-windows@hotmail.co.uk

ALL TRADES  
WELCOME

- INSTALLERS • BUILDERS •
- ARCHITECTS •
- DIRECT TRADE SUPPLIES •
- NATIONWIDE DELIVERY •



HERITAGE  
WINDOWS



HERITAGE  
DOORS

WINDOWS & DOORS HERITAGE 47 - ALITHERM 300-400

BIFOLDS | PATIO DOORS | LANTERN ROOFS | COMPOSITE DOORS



BIFOLD  
DOORS



ARCHED  
WINDOWS & DOORS



INTERNAL  
DOORS

ALUMINIUM  
WINDOW SYSTEMS

heritage-windows  
@hotmail.co.uk

0800-707-6954

## affordable invests in supercut saw centre

timberlook.com 01253 888222.

Affordable Window Systems has invested approximately £250,000 in a new Supercut Saw Centre to increase manufacturing capacity for their highly successful Timberlook range.

Since its launch by a leading UK trade supplier just seven years ago, Timberlook has seen incredible growth, with over 65,000 flush sash Timberlook frames manufactured to date.

To meet this growing demand, Affordable Window Systems has invested in the SC6 model Supercut Saw Centre from Avantek. Unlike typical machines that grip profiles on the inside, the SC6 Saw Centre utilises external gripping for enhanced accuracy and speed, and features three TCT saw blades.

This investment, alongside a new purpose-built multimillion-pound factory which opened last year, underscores Affordable Window



Systems' commitment to further growing the Timberlook range.

Amelia Gaughan, Head of Marketing comments: "This new Saw Centre marks a really exciting time at Affordable. We always strive to produce high-quality products and are continually searching for profitable gaps in the market. Without giving too much away, installers can expect some updates to our Timberlook Flush Sash French and Single Doors styles very soon!"



## crafting quality aluminium arches

smartbending.co.uk

The Smart Bending Company Ltd is a family-run manufacturing business, with a combined knowledge of over 30 years of industry experience. They specialize in providing exceptional aluminium bending services catered to both Installers and Fabricators.



The company prides itself on delivering for their customers. They know the importance of a quality and efficient service, so all enquiries are quoted and returned within 24 hours. Their expert technical knowledge allows them to quote for any bespoke aluminium arch that their customers require. Taking pride in every stage from quoting to aftercare, meaning they offer services that customers trust.

Partnering with industry-leading aluminium suppliers has allowed them to offer aluminium arches to suit a wider range of profiles. These industry leaders include Smarts Aluminium, ALUK, Cortizo, Seniors, and Exlabesa. Constantly focusing forwards, they are always investing in new tooling with the aim to service all customers from all profile systems. They are also happy to work with their customers to try and adapt their current tooling to suit their needs and deliver that quality service.

The company can supply Aluminium Arches as bend only's or fully fabricated arched frames in any RAL or milled finish. Fully fabricated arches include long-leg bends, bowed windows, arched Single and French Doors, or even aluminium arched sash windows. All products are supplied unglazed, with glass sizes confirmed either on order or once

manufactured depending on the complexity of the arch. Glass templates can also be supplied where required.

The Smart Bending company understands that their products are representing the customer's business. Managing Director Terry Gallagher comments "To ensure the best products for our customers we've invested in state-of-the-art machinery and have commitment to consistent quality through the training and expertise of our skilled workforce. Every product leaving the factory is nothing less than what the customer would want in their home."

No matter the customer's location across the country, with a dedicated fleet of delivery vehicles, The Smart Bending Company always ensures products reach them hassle-free, and understand that time is of the essence and the company also prioritizes swift turnarounds, with a 2-week lead time for standard colours and designs.

Terry concludes: "It's our goal to push the boundaries of what is possible. To that end we will always try our best to work with anyone to provide the service they need, in fact we invite a challenge. We very much look forward to building strong relationships with our customers."

# SPECIALISTS

## FOR CASEMENTS, DOORS, HERITAGE SLIDERS, BI-FOLD DOORS, REVERSIBLES & CONSERVATORIES

INTER - STD

MECHANICAL PVC (WINDOWS)  
& VERTICAL SLIDERS

EUROCELL (BIFOLDS)

ALUMINIUM PRODUCTS

BENCHMARK COMPOSITE DOORS

CRAFTSMAN TIMBER DOORS

TOTAL 70C (CHAMFERED)  
TOTAL 70S (SCULPTURED) EDGE  
HERITAGE VERTICAL SLIDERS  
70MM FULLY REVERSIBLES  
R10 FLUSH SASH  
CALIBRE



### Trade Counters

Exeter T 01392 824288 F 01392 824108	Fareham T 01329 284224 F 01329 233116	Paignton T 01803 660239 F 01803 660209
Plymouth T 01752 230080 F 01752 230089	Poole T 01202 735522 F 01202 744460	Head Office T 01803 666633 F 01803 663030



Aspen Way, Yalberton Ind Est  
Paignton, Devon TQ4 7QR





We do more  
so you do less!

# The largest Guardian Certified Fabricator in the UK

Our expanding state-of-the-art factory allows us to deliver high-quality fabrication across the UK.

This includes:

- The highest industry fabrication standards
- All timber cut
- All Metrotile cut
- All screws, fixings and sealants supplied
- All roofs fully build on our factory floor.

## Why choose NECS...

NECS is the largest Certified Fabricator of the Guardian Warm Roof in the UK delivering and supporting installers nationwide. As the leading Certified Fabricator, we pride ourselves on our commitment to high quality and benchmark processes.

- The largest Guardian Certified Fabricator within the UK
- Known for setting the benchmark for quality and professionalism
- Highly advanced fabrication methods to aid ease of installation
- Delivery to installers nationwide

Guardian  
Warm Roof



We commit to our  
customers that we  
do more, so you  
don't have to.

For more information please email  
[info@necsgroup.co.uk](mailto:info@necsgroup.co.uk) or call 0191 622 1527

# WHAT'S DIFFERENT ABOUT GERDA DOORS? ... EVERYTHING!

## FEATURES

### AESTHETICALLY APPEALING

- Gerda doors are available in widths ranging from 840mm to 1130mm, offering a broader selection compared to other doors.
- Colour matched external cill as a standard.

### ENGINEERING EXCELLENCE

- Full aluminium outer frame and Faced with steel for superior durability and resistance
- Gerda RC3 lock with 13 locking points. You can also upgrade the fuhr lock on the Thermo Prime & Altus Range
- Pre-drilled holes supplied with a fixing kit for easy and convenient installation.

### UNMATCHED SECURITY

- State-of-the-art security features with burglary resistance accreditations PAS24 as a standard.
- Revolutionary Smart Tedee Lock App driven by your smart phone device.
- Tedee is the smallest smart lock available

### EXCELLENT THERMAL PERFORMANCE

- Exceptionally energy-efficient, thanks to a unique thermal division that enhances the natural insulation.
- U- values exceed the current and forthcoming Building Regulations with values ranges from 1.3m2k to 0.74k

## TRADITIONAL HAWKSTONE DOOR



**BECOME A GERDA APPROVED  
INSTALLER TODAY!**



## uniting style, fire safety & security

[unitydoors.com/fire-doors/](https://unitydoors.com/fire-doors/)

Unity Doors provides a clear vision when it comes to its composite fire door provision, investing in leading third-party certification to offer a collection which blends style and safety perfectly.

For over 20 years Unity Doors has been the fire door partner of choice for an extensive client base which continues to grow year-on-year.

Driven by innovation and committed to the highest standards, Unity Doors has invested significantly in recent years, in Stuga Machinery, enhanced

manufacturing methods, key partnerships and its employees. Not only has the installation of Stuga's ZX5 Sawing & Machining Centre enabled Unity Doors to boost composite door production by 50% with its precision capabilities, it also underlines the company's commitment to supporting a local economy and UK manufacturing in general.

Additionally, the company has continued to invest in certification, without overlooking all-important aesthetics. Continually looking to ways to bring its customers the best when it comes to style, service, choice and compliance. Today both its contemporary range of composite doors and solid core timber fire doors, brings together exacting design and safety standards.

### Amongst the first to achieve latest SBD requirements

The company is proud to reveal that it is amongst the first fire door manufacturers to achieve the latest Secured by Design requirements for the inclusion of third-party certification of smoke control, in addition to security and fire performance. They firmly believe that this initiative is a major step forward and will result in improved levels of fire performance throughout the industry.

Housing developer, new build, housing association, local authority... Whomever your end client, Unity Doors promises customers that they

can look forward to the highest quality solid core composite FD30s doorsets, as well as timber FD30s and FD60s doors all with fully assured third party accreditation for fire and security.

The manufacturer can also provide a tailored supply and fit service too; from survey, through to manufacture, installation and support, they have extensive experience in Replacement Door Scheme programmes for the social housing sector, so also understand the need to support residents too. Their dedicated and experienced Contracts Managers and Admin Support team oversee projects from start to finish, working closely with customers to help hit project timelines. With diligent, third party accredited (BM Trada Q-Mark) installers, customers can be assured excellent workmanship.

### Survey, supply and install

Working with customers, to their schedule, Unity Door's skilled surveyors will find a suitable time to conduct door surveys. On completion they'll follow a programme of delivery, processing customer requirements and delivering ready-to-install doorsets, to site, to time, ready to be installed by their qualified door installers.

# Link Vent 4000

One of Glazpart's award winning range of trickle vents



New product of the year -  
Link Vent 4000  
Window component  
of the year



Window component  
of the year 2022



For more information and to find your local stockist visit:  
[glazpart.com/trickle-ventilation](https://glazpart.com/trickle-ventilation) | 01295 264533  
or call to speak with one of the team.



Stand out from  
the crowd with  
**police recognised**  
doors or windows



Demonstrate your products achieve  
the highest level of security

Join the hundreds of companies  
who currently enjoy the benefits  
of Secured by Design membership



Secured by Design is the official police security initiative  
Owned by the UK Police Service

Find out more at  
[www.securedbydesign.com](http://www.securedbydesign.com)



# premier windows & conservatories celebrates 35 years of excellence

[conservatoryoutlet.co.uk](http://conservatoryoutlet.co.uk)

After seeing an advert in a local magazine, the husband-and-wife team of Paul and Caroline Chenery took a chance. They jotted a telephone number down, had a conversation and started Premier Windows & Conservatories.

That was in 1989, a year that saw the debut of Sky Television on British television screens and the first proposals of what a 'world wide web' could look like.

A lot has changed in the years since.

But Premier hasn't changed a great deal. Sure, the premises are now bigger and its customer base is now far larger than it was in those early days, but the Oswestry-based installer of windows, doors and living spaces has remained committed to providing a truly first-class service and ensuring the company is family-run.

"Since starting the company all those years ago with my husband Paul," Caroline begins, "we've ensured that Premier has a real family feel. Even with our growth and expansion, we've kept family front and centre."

"We think it's incredibly important to do so at a time when that's becoming increasingly rare in the industry. It also allows us to blend those family values with our ethos of improving every home; it's something that really resonates with our customers."

After enjoying further growth, Premier relocated to bigger showrooms twice - first in the early 1990s and then again in the late 2000s. In 2008, the company joined the Conservatory Outlet Network, enabling them to benefit from an exclusive product range, marketing support and further investment in their Oswestry showroom

Today, Premier stands as the sole Premium Retailer in the area, having just been audited and accredited by the Yorkshire-based manufacturer.

"We're thrilled with the ongoing support of Conservatory Outlet," Caroline continues.

"They've helped us a great deal, enabling us to grow and get to the point where we can celebrate 35 successful years as a family business. Looking to the future, Premier's focus will always be the same it has been:



transforming homes, providing the best service possible and putting family first."

It's with the future in mind that Caroline has recently announced that she'll be following in the footsteps of her husband Paul and taking a step back from the business they founded 35 years ago.

However, Premier will remain within the Chenery family as Paul and Caroline's eldest son, Ben, will continue to run the business. Ben started his career as a fitter, before becoming General Manager in 2013 and then becoming a Director four years later.

Ben will be joined in the day-to-day running of Premier by his wife, Kelli, who recently joined the company after working in HR for a nationwide company. She'll be responsible for the day-to-day management of the office and will become the first point of contact for customers, whilst Ben will continue overseeing Premier's installations and the operations side of the business.

"I'm delighted that Kelli has joined Premier Windows & Conservatories," explains Ben. "Premier has been a family business for the past 35 years and as we celebrate this important milestone, I'm glad that we've ensured Premier will continue to be family-owned and family-run long into the future."

Speaking about Premier's 35th birthday and the change of management Conservatory Outlet CEO, Greg Kane, commented: "We feel extremely privileged to have worked with Caroline, Paul and Premier since 2008 and witnessed their incredible growth over the years. Premier has stood the test of time to become the best installer in the area."

Greg added: "I wish Caroline a very happy and well-deserved retirement and I'm thrilled that with Ben and Kelli at the helm, they'll continue to provide their customers with a top-class service. I look forward to many more years of a successful relationship with them."

**smart**  
architectural aluminium  
Authorised Manufacturer

HERITAGE  
ALUMINIUM  
DIRECT

**NEW**

## ALU-SPACE Internal Room Divider



## ALUMINIUM HERITAGE 'STEEL REPLACEMENTS'



**DOORS**



**BIFOLDS**



**WINDOWS**

**ALL TRADES WELCOME**

**01322 587612**

[SALES@HERITAGEALUMINIUMDIRECT.CO.UK](mailto:SALES@HERITAGEALUMINIUMDIRECT.CO.UK)

[www.heritagealuminiumdirect.co.uk](http://www.heritagealuminiumdirect.co.uk)

# the benefits of sbd membership for door & window companies

securedbydesign.com

Working to improve the physical security of buildings using Secured by Design (SBD) accredited products is the reason so many door and window companies are seeing huge benefits in SBD membership.

There has been a significant growth in demand for advice and requests for details of companies that have membership with SBD, which has been evidenced in the increased traffic to the SBD website and the reported increased sales of SBD member's products.

**Knowing that a product is fit for purpose is critical.**

The accreditation scheme Secured by Design operates on behalf of the UK Police Service, provides a recognised standard for all security products, ensuring that they are sufficiently robust to resist physical attack by casual and opportunistic burglars. It is the only way for companies to obtain police recognition for security-related products in the UK.

The SBD focus is on the critical factors that combine to deliver a product's performance - design, use,

quality control and the ability to deter or prevent crime - and these products or services are known as being of a 'Police Preferred Specification'.

In addition, the Police Preferred Specification requires regular re-testing and annual inspection of the manufacturing facility (Factory Production Control) to ensure quality and performance are maintained. This provides assurance that products have been produced under a controlled manufacturing environment in accordance with the specifier's aims and minimises misrepresentation of the products by unscrupulous manufacturers/suppliers and leads to the delivery, on site, of a more secure product.

Every day Police Designing Out Crime Officers are collaborating closely with builders, developers, local authorities and housing associations to incorporate SBD's police crime

prevention standards into buildings. The police service signpost customers looking for security products to securedbydesign.com, where a comprehensive list of the 700 companies that produce the products that meet SBD Police Preferred Specification can be found. Each company has its own page on the SBD website giving full details of the

company, contact information and a detailed list of all their SBD accredited products.

SBD represents a powerful, trusted brand which inspires greater public confidence in products. For SBD membership or technical enquiries, visit [securedbydesign.com/contact-us/sbd-membership-and-technical-enquiries](http://securedbydesign.com/contact-us/sbd-membership-and-technical-enquiries)



# Seasonmaster

Bi-Folds, Patios and Secondary Glazing



**PRICE REDUCTION ON BIFOLDS  
DUE TO INCREASED CAPACITY Call for details**

**WE ALSO MANUFACTURE  
ALUMINIUM SECONDARY GLAZING**

As a family run business, we offer a personal touch and most importantly a good price

**www.seasonmaster.com** Call **01252 319670** Fax **01252 341983** Email **sales@seasonmaster.com**

## ALUNET ALUMINIUM PATIOS & BIFOLDS

- ✓ Sashes up to 2.5 x 2.7m (Patios) & 1.2 x 3m (Bifolds)
- ✓ U Values from 1.4 U W/m<sup>2</sup>K
- ✓ Weather proofing BS6375 Part 1 : 2009
- ✓ Single or dual colours to any RAL (Stock: White, Grey, Black, Black on White, Grey on White)

**ALL PRODUCTS  
MANUFACTURED  
IN OUR FACTORIES**

**MADE IN  
BRITAIN**



Wouldn't you like more time on a beach  
and less time stressing about windows?

**Partner with Pioneer** and this dream  
can become the reality

-  **Premium Deceuninck products**
-  **Right first time**
-  **Fast lead times**
-  **Exemplary customer service**
-  **A friendly team that genuinely  
want to help you succeed**

If you want a **trade supplier** that genuinely **puts you first**,  
call our friendly team at Pioneer today

**01245 362236 | [sales@pioneertc.com](mailto:sales@pioneertc.com)**

**deceuninck**



**door-stop**



# carl f groupco's my cfg streamlines the hardware buying process

[carlfgroupco.co.uk](http://carlfgroupco.co.uk)

**Independent hardware distributor Carl F Groupco has reported a rapid increase in the number of users of its innovative online platform, My CFG. Launched in August 2022, My CFG was designed to make the hardware buying process as seamless and efficient as possible for its customers.**

Clare White, Marketing Manager explains: "In today's digital age, online purchasing has become second nature in both our personal and professional lives. Recognising this trend, we tailored My CFG to meet the evolving needs of our trade customers by offering a wide range of functions, including online ordering, access to account information such as invoices and statements, pricing and secure payment options. From the start, we

have ensured that the platform delivers tangible value through a user-friendly interface and seamless processes. With the number of users doubling in the past twelve months, it is pleasing to see our customers embracing the platform's many features and comprehensive functionalities."

The easy-to-navigate platform works across desktop and mobile devices and users can access the portal 24/7/365. Orders are linked directly to Carl F Groupco's ERP system which speeds up processing times and ensures there are no administrative errors.

Luke Handyside, Factory Manager at Addspace Construction Ltd, said: "My CFG has changed the way that we purchase our hardware from Carl F Groupco. We can order anywhere, anytime and have access to our customised product list and pricing. It's made purchasing hardware less time-consuming and less of a chore."

Despite the undeniable benefits of My CFG, Carl F Groupco remains committed to the importance of human interaction in building strong customer relationships. Andrew Price, Regional Sales Manager for South-West England said: "My CFG helps our customers, but it also helps us too. Steve Lee, our Internal Sales Co-ordinator, and I have more time to deliver value-added support to our customers where we can provide our



technical expertise. We have built our reputation on outstanding, above and beyond customer service and My CFG is not a replacement but an extension of that service commitment."

Carl F Groupco places a strong emphasis on providing a proactive customer focussed service which extends to bespoke labelling, repackaging into hardware sets and breaking down box quantities for additional flexible support. The company also offers product testing support to its customers, ensuring a seamless process from product

selection and sampling to manufacturing, testing and post-test advice. In addition, the company will utilise its relationships with hardware manufacturers, collaborating on product development to help give fabricators and installers the hardware features they need for the UK market.

Clare concludes: "The growing popularity of My CFG is testament to our dedication to meeting and exceeding customer expectations by providing exceptional service and support, both online and offline."

## Modern Aluminium Bifolds with Slim Sightlines

Easy installations with pregasketed bead and integrated cill option

All materials fully stocked for a **Fast Turn Around**

**Jig Fabricated** - Allows quality & function checks prior to delivery



01543454242 (option 4)  
sales@pyramid-profiles.com



**STANDARD COLOURS**  
7016,9910,9005 & 7016/9910

**7 DAY NATIONWIDE DELIVERY**

**LIMITED OFFER**  
**£470**  
+vat per leaf  
**INCLUDING GLASS**  
new customers only



# record levels of roofing interest

supaliteroof.co.uk

SupaLite are reporting a huge jump in enquiries and orders for the I Lite Flat Roof Orangery System, along with the new S1 and S2 Conservatory Glass Roofs.

In January 2023, SupaLite opened a new manufacturing plant, dedicated to the I Lite Flat Roof Orangery, Sheerline S1 Roof Lanterns and the S2 Conservatory Roof.

Q1 results in 2024 for the new plant have shown vast increases in output, with a record growth of 58% year on year. Steve Hacking, Managing Director states: "Our high-performance Orangery Roof System and revolutionary S1 and S2 Systems have been well received by both customers old and new. The record levels of interest show our customers have the confidence in our ability to manufacture four completely different products whilst maintaining our seven working day lead time."

SupaLite have also recently launched their new Double SkyVista, featuring a newly designed rear soaker to remove the need for typical lead soakers. This speeds up the installation of the SkyVista feature panels to less than 20 minutes, saving time on site when compared against other systems.

The SupaLite Roof System continues to maintain high levels of demand with installers looking for the high value contracts associated with the replacement roof market. With over 5 million conservatories in the UK, there is a huge attraction for homeowners wanting to improve rather than move, especially whilst mortgage interest rates remain high. Both the SupaLite roof and the I Lite are easy to install and fully accredited for Building Regulations approval,



achieving a U-value of 0.15 for England, and an optional upgrade to 0.12 for Scotland and 0.13 for parts of Wales. This month, they have also introduced the option of ordering a Building Regulations certification when customers place a roof order. SupaLite installers will find this scheme incredibly beneficial, as it takes away the time and hassle. SupaLite's administration team process the applications on behalf of their customers, making the process quicker and easier.

Having partnered with Hertfordshire Building Control (HBC), SupaLite can now offer certification for installations in England.

SupaLite are also pleased to announce a new roof tile will be available in the coming months to run alongside their ExtraLight Shingle and Tapco slate. This will provide an additional finish to allow their customers even more choice.

Steve Hacking adds: "With interest skyrocketing, our range of replacement conservatory roof systems can provide ambitious installers with a valuable route to market and good profit margins."

# 25 year furniture guarantee

01634 263263 sales@vbhgb.com

VBH, the hardware specialist behind the greenteQ range, has announced a brand new guarantee that covers the greenteQ residential door, patio door and window furniture range for up to 25 years.

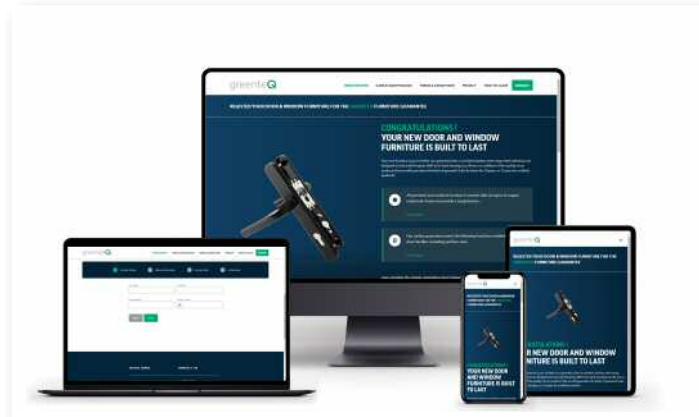

The popular greenteQ furniture range has now been split into two separate groups. The stainless steel architeQ range covers furniture for residential doors and patio doors, with the mainstream greenteQ Suite covering the same but with the addition of window furniture.

The surface finish on greenteQ Suite products has been increased to 20 years, with a 25 year guarantee available on architeQ furniture.

In addition to these extended guarantee periods, where the guarantees really stand out is that, for what they term 'qualifying customers', VBH will deal with any claims directly with the consumer, leaving the fabricator and installer free to do what they do best; make and sell windows and doors.

VBH advise that they are able to offer these guarantees based on what they describe as greenteQ furniture's "excellent performance in test lab conditions, and real-installation experience."

Head of Brand, Dan Powell, says, "Two big headaches reported by manufacturers and installers are firstly, having to send an engineer to site to investigate and rectify a problem and, secondly, being unsure as to what the guarantee on a particular product or finish actually is! It really isn't as simple as it should be. We have made our guarantee as transparent as possible. Depending on the product, it's 20 or 25 years, and we will take care of the whole claim and replacement process direct with

the consumer for qualifying customers, so they can fit greenteQ and forget.

"As well as taking the hassle out of dealing with any claims, the 20 and 25 year terms give everyone in the supply chain absolute assurance that greenteQ furniture is built to last, and that as the furniture manufacturer we will stand by the product. Our aim is to help installers turn enquiries into sales."

VBH advise that many qualifying companies are already taking advantage of the 'fully serviced' guarantee, with many more in the pipeline. They urge interested companies to get in touch to discuss the details directly.



Here to help you

# Get a Better Deal

NATIONWIDE SERVICE

7.30 - 21.30  
Open 7 Days  
Per Week

PVCu  
Aluminium  
Hardwood  
Aluminium Clad Timber  
Lanterns  
Conservatory Roofs  
Flat Roof Vents  
Veranda's

01332 412002 Midlands  
01642 927755 North  
0118 9071514 South  
0117 9269451 West & Wales  
enquiries@tpltrade.co.uk



Aluminium & PVCu  
White or 7016 Anthracite  
Grey inc DUAL Colour  
Bespoke sizes  
10/14 Day UK Delivery



Associated Company

Aluminium Doors



Bifolding  
Patio  
Residential  
Commercial  
Composite  
Stable  
Automatic

www.aluminiumdoorsuk.co.uk

# Embrace the elegance

## Classic

### HERITAGE DOOR

Available as a single or French door, with slim sightlines the Classic door offers the modern levels of performance that Building Regulations demand, all in a product with an aesthetically pleasing timeless look.



Period inspired lock box design



Easy to fit clip-in bead



**SGM**  
"Excellence in aluminium"

For more information contact our Sales Director  
Phone: 01268 285544 • Fax: 01268 284433 • E-mail:  
Honywood Square, Honywood Road, Basingstoke  
[www.sgmwindow.com](http://www.sgmwindow.com)

# of heritage style doors



Ideal for both modern and traditional style properties



Stuart Bull on 07789 692340  
Email: [stuart@sgmwindows.co.uk](mailto:stuart@sgmwindows.co.uk)  
London, Essex SS14 3HT  
[www.sgmwindows.co.uk](http://www.sgmwindows.co.uk)



## staying ahead of the curve

sheerline.com 01332 978000

Sheerline's commitment to continual investment has seen the installation of a £270,000 TIM-ING Profile Bending Machine at its' Derbyshire HQ. As a result, the company is offering a new specialist profile bending service, enabling fabricators to order perfect arched, curved and round windows.

This latest expansion of capabilities is all part of Sheerline's strategic commitment to continual investment, ensuring its' facilities remain technologically advanced, and helping the company's customers to stay ahead of their competition.

TIM-ING's equipment offers some of the most advanced bending machinery for aluminium and PVC profiles in the world. There are 3D cameras within the machine, which enable it to be automated for efficiency and to ensure repeatable quality.

This announcement coincides with a growing demand for arched windows. Sheerline understands that properties with character and heritage features require specialist solutions that ensure homeowners can renovate properties sympathetically, without compromise.

Sheerline prides itself on offering bespoke services to its fabricator partners, because it understands how important it is for fabricators and installers to be able to match their customers



needs'.

In addition, customers can choose from standard, custom, or dual colour choices without increasing lead-times. Providing an agile, robust service by keeping everything in-house, from aluminium extrusion to painting, and now profile bending.

Technical Production Director, Ross Hartshorn, said: "This announcement, and the installation of our specialist profile bending machine, is another step in our strategic investment plan that ensures we stay at the forefront of the aluminium industry – it's one of the things that differentiates us from other manufacturers."

"There's a reason we've gained a reputation for being an industry leader in such a short period. We aren't afraid to take on historical challenges and offer solutions that benefit our customers," he added.

## jobs board plays matchmaker

ggf.org.uk

As the shortfall in skilled labour continues to be an issue for the fenestration industry, the GGF and FENSA are pleased to announce that their combined jobs board is helping to match companies with vacancies to fill, with suitable candidates.

The Glass and Glazing Federation (GGF) and FENSA officially launched the jobs board in February and just a few months on are pleased to report that the forum is being populated. Chris Beedel, Head of Advocacy & Stakeholder Relations at the GGF explained: "In the relatively short time the jobs board has been live, it has seen 54 jobs posted and 40 applicants looking for work and we are confident that these numbers will continue to grow.

"We created the jobs board because our members told us they were struggling to fill vacancies, and yet we knew there were also plenty of people looking for work. The board that sits on both the GGF and FENSA websites holds current job vacancies as well as profiles of candidates that are looking for work. The system actively matches job seekers with positions that are suited to their skillset and requirements. Of course, the more companies and people that use the jobs board, the more useful it will become as a resource. GGF members can post jobs on the board for free, but non-members can still use the facility for a fee. Meanwhile individuals looking for work are notified when new jobs matching their criteria are posted, or when new relevant training courses are launched."

### uPVC Panel



All RAL Colours  
3 Day Turn Around  
In House Glass Shop  
For Customised Designs

### Composite



THE OVAL  
DOOR  
EXCLUSIVELY  
MANUFACTURED  
IN THE UK BY  
BDP

eurocell

Eurocell Profile  
Fab N Fix Handles  
Entrance, French & Stable in 29 Colours

from

£350

### Bifolds



Aluminium

smart  
architectural aluminium

Any Single or  
Dual RAL Colours  
Smart Approved Hardware

from

£375

**Your Door  
Specialist  
Manufacturer**

**BDP**  
**B'HAM**  
**DOOR PANELS LTD**

**0121 525 0110**

orders@birminghamdoorpanel.com

www.bhamdoors.co.uk

fax 0121 525 0199

# HOW DO YOU IMPROVE ON PERFECTION?



## GIVE IT A NAME

Find out more:



[WWW.ICENIWINDOWS.CO.UK](http://WWW.ICENIWINDOWS.CO.UK)



# how do you improve on perfection? give it a name

[iceniwindows.co.uk](http://iceniwindows.co.uk)

Iceni windows in essex have launched five brands to cover five product divisions; Upvc windows, aluminium windows, Flush uPVC windows, Roofs, and Doors. Each product division has a new name and a unique colour in which to identify it by

A new branding philosophy came about when managing director, Paul Foyle, felt his products were seen as merely adequate equals in the market, when in fact he was convinced they were more:

"The confidence we have in our manufactured products has always been there. The performance and quality is self-evident – just ask any of our customers from the last 22 years. This quality comes as standard."

"The requirement for a brand that supports this ethos was essential: We knew we had to create something special that supported our convictions. Giving them each a brand name attains this necessary level." says Paul Foyle, Managing Director,

### A brand conceived from self belief

It's an innovative approach within a visually noisy and cluttered marketplace. One we hope is much easier to understand, and customers can revitalise their belief in a fresh branding suite. It differs enough

to other brochures for them to be better equipped when it comes to sitting down and closing a sale with the end user.

"Our customers are using the same tired brochures and images as everybody else and this is detrimental to how our product is perceived throughout the market. The brand had to match its quality and so I designed a concept that takes on a high-end feel. A sleekly branded unique brochure suite makes for a fresh image to bring to the homeowner"

We're promoting the awareness of how well they are made, and currently no other company has this level of aesthetic for their output." explains Quentin Radburn, Marketing Manager and primary creator of the brand.

However, Iceni are keen to stress that they're not undermining the existing strength of the brands they already use, like Rehau or Residence.

Lee Delapperall, Sales Director, explains, "There is a lot of value attached to the brands of the systems

we use and we value the relationships with our suppliers greatly. They are all aware of what we are building and support our newly formed brands.

"The intention is not to sell a different product, but rather accentuate their level of manufacture. It's comparable to a designer product in that it has the same function, but you know it is in a different class."

### "A sleekly branded unique brochure suite makes for a fresh image to bring to the homeowner"

"These are the same products, but transcend others by simply being made better. Iceni products will meet – and exceed – demands of multiple applications. Everything is encompassed within the range; white upvc to bespoke roofing. Heavy duty and light commercial aluminium for new builds, large-scale refurbishment projects and residential new builds can be catered to."

The website and brochure suites will be live and available on May 1st



# THE ICENI BRANDS



## All standard **REHAU UPVC** windows and doors

[www.raya-windows.co.uk](http://www.raya-windows.co.uk)

- **REHAU**  
uPVC Casement  
Bay windows  
Tilt n Turn windows  
Vertical sliders  
French doors  
Resi doors  
Reversible windows  
Patio doors



## All **FLUSH UPVC** windows and doors

[www.aeon-windows.co.uk](http://www.aeon-windows.co.uk)

- **RESIDENCE**  
R9 flush windows  
R9 flush doors  
R7 flush windows  
R7 flush doors  
R2 flush windows
- **REHAU:**  
RIO flush windows  
RIO flush doors



## All **ALUMINIUM** windows and doors

[www.aura-aluminium.co.uk](http://www.aura-aluminium.co.uk)

- **ALUK:**  
Bi-fold doors  
Patio doors  
In-line sliding doors  
French doors  
Resi doors  
Lift & slide  
Commercial doors



## All **COMPOSITE DOORS**

[www.riva-doors.co.uk](http://www.riva-doors.co.uk)

- **DOORCO:**  
Composite doors
- **SOLIDOR**  
Composite doors



## All **ROOFS**

[www.luna-roof.co.uk](http://www.luna-roof.co.uk)

- **ULTRAFRAME:**  
Classic roofs
- **PLUS**  
Flat rooflights  
Lantern roofs



## successful sales & marketing event

[conservatoryoutlet.co.uk](http://conservatoryoutlet.co.uk)

Leading premium retailers from across the fenestration sector gathered at Old Trafford in Manchester last month to attend Conservatory Outlet's latest Sales & Marketing Conference.

Held annually, this event brings the network of retailers, alongside respected industry figures, Conservatory Outlet's sector-leading marketing team and digital agency, as well as key business partners together to discuss the latest trends and strategies that are shaping the home improvement market.

With the former European Champion's pitch as the backdrop, presentations covered a wide range of topics including the highly anticipated launch of Conservatory Outlet's Premium Retailer campaign and an

overview of marketing trends and analysis from leading digital marketing agency, DigitalKOG.

Additional presentations focused on unique product demonstrations and insights, sales techniques and how best to maximise new and emerging sales and marketing channels.

All presentations and speakers were chosen to allow attendees to learn, network, and gain practical knowledge to drive business growth.

Conservatory Outlet's CEO, Greg Kane, reflecting on the conference's success, remarked: "It was great to see so many people join us in Manchester, and I've received nothing but praise regarding the content and the team's organisation."

"This year's Conference has been our highest-rated and highest-attended yet. We put a great deal of effort into designing a tailored agenda, covering both macro and micro topics relating to both sales and marketing."

Andy Hill, Director at TWC Home Improvements, adds: "It was a fantastic event. The case studies presented by Conservatory Outlet and DigitalKOG were extremely useful, the external speakers were engaging and there I learnt today that I can take back



to my business. "Working with Conservatory Outlet allows us to attend these events and gain new insights and analysis about products, services and the wider market that we simply can't get anywhere else."

The Sales & Marketing Conference followed in the footsteps of two widely successful Operations Conferences in February. It will continue to be supported by the company's ongoing monthly marketing and social media training, as well as our well-attended best practice sessions that have a more operational focus."

Additionally, Conservatory Outlet has also announced it is expanding its

Sales Training programme in a bid to further enhance its retailer's sales teams.

"It's an exciting time to be part of the Conservatory Outlet Network," concludes Greg.

"Both leads and sales are up year-on-year across the Network and we're working hard to ensure that our Premium Retailers can continue outperforming the competition.

"Events such as this give our customers the ideas and strategies they need to succeed and we look forward to helping them grow their market share further."

## free network membership

[www.bestlocalinstaller.co.uk](http://www.bestlocalinstaller.co.uk)

The software developer behind the consumer review website, [allchecked.co.uk](http://allchecked.co.uk), has launched the Best Local Installer Network to promote independent local window, door and conservatory companies exclusively in their home towns and cities.

To celebrate the launch, All Checked is offering free network membership to the first 25 applicants. Members' benefits include:

- A guaranteed regular supply of free and exclusive, price-conditioned sales enquiries, with numbers predetermined at the outset.

- A free Lifetime Warranty for every customer, which can be handed out at the point of sale to boost sales conversion rates. The Lifetime Warranty will take effect when the member's guarantee expires, and all claims will be covered by All Checked.

Managing Director, Greg Allen, said, "It's high time that reputable local installers who consistently deliver high levels of quality, service and value, got the recognition they deserve.

The Best Local Installer Network will champion some of the best small to medium enterprises by creating a national brand with a local presence to support them.



By appealing to all consumers, including those who might otherwise favour the 'big-name' companies, the network will bring more sales opportunities and better profits to its members." Network members will be offered full and unrestricted access to all of the company's software tools,

which are provided on a pay-on-results basis and backed by a cast-iron money-back guarantee.

Interested parties are urged to make enquiries via the website, [bestlocalinstaller.co.uk](http://bestlocalinstaller.co.uk), at the earliest opportunity to avoid disappointment.

## aluk bsf70 gets new handles and a new cill

[aluk.com](http://aluk.com)

ALUK has announced some significant enhancements to its popular BSF70 HI bifold door, designed to give customers even more choice and flexibility.

There is now a surface-mounted lift and turn handle available as an alternative to the more traditional pop-up T handle, and a new easy to install integrated cill.

The new easy to operate, easy to fit lift and turn handle provides what AluK says is the ideal combination of value, aesthetics and functionality and comes in white, black, silver, chrome and anthracite grey to suit any of the BSF70 HI colours.

The integrated cill uses the existing nose projection from AluK's premium F82 bifold and gives the iconic BSF70 HI a new look with a two part profile for the first time. Because it is added last, the cill eliminates any potential damage on site. It also means, for the new build or extensions market, it removes the need for the builder to cut out the existing brick course to achieve a level internal floor finish with a rebated frame.

Russell Yates, Managing Director of AluK, commented: "We're continually improving and enhancing all our



products to keep pace with customer demand and a changing market.

"As we've already shown with the launch of the Quik Clip clip-in bead for

the BSF70 HI, even with our best-selling products there's no room for complacency as we constantly look to stay ahead of the competition."



# A GUARANTEE IS ONLY AS GOOD AS THE COMPANY OFFERING IT

MANUFACTURING SINCE **1998** WE OFFER

**10 Years - Windows**  
**5 Years - Glass**  
**2 Years - Hardware**

NEW NEW NEW NEW NEW NEW NEW NEW NEW NEW NEW NEW NEW NEW

*We Now Manufacture*

## ULTRA SLIMLINE ALUMINIUM WINDOWS

ALT W73 CW



**1.1**  
**W/m<sup>2</sup>K**  
(Triple Glazed)

Outstanding  
tightness  
performance

**Anodized  
Options**  
(bead blasting,  
brushing &  
polishing)

**Any RAL  
Colour**

CALIBRE WINDOWS  
**CWC**  
& CONSERVATORIES  
TRADING SINCE 1998

UPVC Windows, Doors & Sliders | Aluminium Bifolds | Composite Doors

call **0121 359 4412** online [www.cwcwindows.com](http://www.cwcwindows.com)  
email [info@cwcwindows.com](mailto:info@cwcwindows.com) fax **0121 359 4413**



See more  
photos &  
customer  
reviews



Calibre Windows & Conservatories Ltd



# Warmer Roof, the only timber roof system to be LABC approved

Now offering  
in-house building  
control applications to  
all new and existing  
customers

*... Take advantage!*

## HERE TO TAKE THE STRESS AWAY

- ✓ LABC APPROVED - IN-HOUSE APPLICATION SERVICE
- ✓ 5 DAY TURNAROUND
- ✓ BECOME A REGISTERED INSTALLER
- ✓ NEW TRADE SUPPORT & MARKETING PACKAGE



**25 YEAR  
MANUFACTURER  
WARRANTY**

# The hassle-free solution to obtaining LABC approval on your Warmer Roof project

## What's **NEW** for 2024?

Warmer Roof are offering a brand new service which comprises of in house building control, allowing all our customers the advantage of a comprehensive service and peace of mind knowing the entire process is expertly taken care of.

**SAP calculations available**

**SEND US  
YOUR QUOTE  
AND WE WILL  
BEAT IT**

## Tried Tested & Trusted

The Warmer Roof has undergone extensive testing processes to ensure the system not only meets building regulation requirements but exceeds and outperforms like no other system, providing long lasting thermal efficiency achieving a U-Value as low as 0.12. All results are submitted and approved by LABC.

**Includes:-  
Genuine U Value and condensation risk analysis  
credentials conducted by Elmhurst Energy**

### U-VALUE CALCULATOR REPORT

#### Warmer Roof Standard

Total thickness: 224mm U-value: 0.15 Wm<sup>2</sup>K

#### Warmer Roof Plus

Total thickness: 254mm U-value: 0.12 Wm<sup>2</sup>K

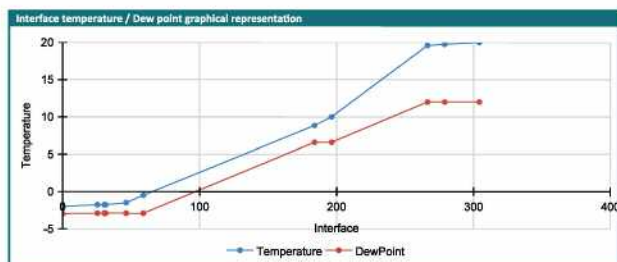

Enquiries: **01373 473 900**

**sales@warmerroof.com**  
**buildingcontrol@warmerroof.com**

# what is a blog and why should i care?

blogwrite.co.uk

Director of Blog Write and copywriter to the glazing industry for over 20 years, Helen Savage offers some insight into blogging as a business and explains why it's the perfect form of content marketing for the window industry.

For as long as I have worked in marketing in the window industry, I have been party to discussions about the best way to reach consumers. Whether its systems companies that want to create pull through for their brand, or installation businesses that want to elevate their reputation in the local area, consumer reach is often the Holy Grail.

The idea of TV advertising is always raised and then quickly discarded because of the expense and because of the volume needed to make an impact. Social media is considered and sometimes initiated, but the volume of messages in this space has made it increasingly difficult to be heard. So, what about setting up a blog on your website? Useful, or useless?

The statistics say useful. End users appreciate them with 80% of internet users interacting with both blogs and social media sites and 70% of consumers saying they would prefer to learn about a business from a blog rather than an advert. And if we want to get down to the brass tacks of value for money, according to DemandMetric, companies with blogs produce an average of 67% more leads than companies that don't blog.

## Challenging perceptions about blogging

So, what is a blog? The word blog comes from the longer phrase 'weblog' and means a discussion or information text on the web. Blogs are often more informal in their tone and are published regularly for the greatest impact. A lot of people still associate blogs with individual bloggers and while this was true in the early 2000's, by 2010 political organisations, news outlets and businesses had all joined the blogging community.

Authoritative and consistent blogs that talk intelligently about your industry and products mean that web visitors are more likely to trust your opinion and contact you for general advice, which then of course opens the door for new business. Today companies successfully use blogs to raise their profile, boost leads, demonstrate thought leadership, and position themselves as experts.

## A cost-effective option

As well as the multitude of benefits that blogging can bring, it is also a cost-effective option to employ. Once you have the facility for a blog set up on your website you can publish content for free as often as you like, using posts written by employees with different expertise across the business, an internal marketing resource, or a specialist marketing copywriter whose only job is to write content for your business blog. Window and door companies that are already blogging are ahead of the game and enjoying the benefits of this important part of any digital marketing strategy.

For more top tips about copywriting for your business or creating and maintaining a business blog, visit [www.blogwrite.co.uk/blog](http://www.blogwrite.co.uk/blog).



 **BlogWrite**  
Helen Savage  
Director

# avoid disputes on poor acoustic performance

[risaltd.co.uk/pulse-testing-trickle-vents](http://risaltd.co.uk/pulse-testing-trickle-vents)

**RISA has highlighted the benefits of pulse testing for window installations in properties where improved acoustic performance is the primary objective, but where customers are actually reporting worse noise levels, post installation, due to the specification of trickle vents.**

RISA offers its pulse testing service to all installers. It was introduced following the update to Approved Document F for ventilation and indoor air quality, legislation that typically requires the use of trickle vents to be incorporated into new windows and doors.

Pulse testing, however, is designed to demonstrate the airtightness of a building pre and post installation, and in many cases when the reading doesn't change, it provides installers with certified evidence

to prove there is actually no requirement for additional trickle vents. For installation projects on buildings that are located close to busy roads or under flight paths, where customers are paying for a high-quality solution to reduce the amount of noise into their property, pulse testing provides a valuable alternative route to compliance by significantly reducing the chance of customer disputes.

Lee Galley, Independent Inspection and Assessment Manager for RISA, said: "We've had a spate of inspection requests recently for installations where noise infiltration is the main cause of the dispute.

"These have primarily been for projects where improved acoustic performance was the main reason for purchasing new windows, and where the specification includes acoustic rated glass, but the homeowner is adamant that noise levels are worse compared to the old windows.

"In most cases, this is because trickle vents have also been included in the specification," he continued. "Installers should be commended for doing their best to follow the regulations, but they should also be made aware that trickle vents are not always necessary and in fact can result in disappointed customers who are paying a premium for a quieter and more comfortable home.

# conservatory outlet hosts successful conferences

[conservatoryoutlet.co.uk](http://conservatoryoutlet.co.uk)

**Conservatory Outlet, UK fabricator of home improvement products, is looking forward to hosting several more Network-wide events after its series of Operations Conferences has proved to be a real boost to its retail Network.**

The events, held in both Glasgow and Birmingham, allowed members of the fabricator's Premium Retail Network to come together to discuss industry-specific challenges, changes to Building Regulations, regional legislation, and other topics relating to their businesses.

As part of the round-table forums, Conservatory Outlet invited several guest speakers to present on a range of topics, including innovative new construction methods and other operational matters.

CEO, Greg Kane, commented: "Our unique model allows for events like this to take place where everyone comes together without the fear of competition. The turnout for this year's events in Glasgow and Birmingham was phenomenal, with over 90% of our Retail Network represented by key personnel.

"These events allow everyone to share their knowledge and expertise and work as one to provide solutions that benefit all involved. They are an incredible tool and have a widespread positive impact across our Network of Premium Retailers.

Internal feedback scores from the two events have reached a 96% satisfaction



level, with the attendees praising the organisation, locations and discussion topics. One such attendee was Stewart Kelly, the Managing Director of Eden Windows, who said: "It was another fantastic example of the support that Conservatory Outlet provides.

"The guest speakers were informative, and the wide range of topics that we discussed covered everything from product design to health and safety to the structure of contracts. Being able to ask questions, get answers and see what similar companies to Eden are doing is extremely beneficial. It gives us attendees the chance to learn from each other, share best practices and help each other improve."

Plans are already underway for next year's events, though the immediate focus is on the company's upcoming Sales & Marketing Conference, which will be held at Old Trafford stadium later this month.

Greg ended by saying: "With our annual Sales & Marketing Conference on the horizon – and many more events planned through the rest of the year – we're continuing to provide value-added benefits to our Network members to ensure that they will continue to thrive in a competitive marketplace.

"Conservatory Outlet isn't just a manufacturer or supplier – it is so much more. We equip all our retailers with the tools and information they need to succeed."

# MaxiLite

## Aluminium Skylights



**Maxi-Flat**

**Maxi-Hipped**



**ELECTRIC**  
Flat Roof

Maxi-Opener  
2m x 1m - Glazed  
**£1,795**

**Slim and fast to install...  
less really is more!**

Add the beautiful MaxiLite range of Aluminium Skylights and Verandas to your product range and showroom.

[info@maxilite.co.uk](mailto:info@maxilite.co.uk)  
01268 385511



**FITS IN  
MINUTES**

**TRADE  
ONLY**  
prices

**INSTANT  
QUOTES**  
with our app

\*All prices ex vat



## new research projects director

[mra-research.co.uk](http://mra-research.co.uk)

MRA Research, the research agency focused solely on the construction sector, welcomes Callum Budd as its new Research Projects Director.

Callum brings to the role a wealth of experience in market research. He has held several positions within market research over the past 12 years and has managed a large number of research projects, including customer satisfaction and brand awareness projects. Most recently he supported global IT and Technology vendors, including Dell and IBM, with their research needs. In his new role, Callum is responsible for the planning and management of all research projects, from commissioning new business through to the presentation of results, and manages the research team. He will also develop and deliver the broad range of research products and services offered by MRA Research.

Callum says: "I'm excited to join Mike and the amazing team at MRA Research and eager to help build on their current success. Together we are well-equipped to support a wide



range of research needs. I'm optimistic about the potential and future growth of the construction industry and excited about MRA's own trademarked research products, the Management Mirror and the Customer Experience (CX) suite. A growing number of companies measure their performance using the Net Promoter Score (NPS), and large companies often link managers' bonuses to it. NPS is a powerful metric, and shows you how you're doing compared to all firms in all major markets in the US and Europe. But, comparing construction companies with average scores, from mostly B2C companies of all sizes, isn't particularly helpful. Our customers want to know how they compare with companies in similar building materials markets. They also want to know how to improve their scores. That's why MRA Research has been building norms for this industry, so firms can tell how they are performing.

## nbp pioneers transparency in construction

[nbp.co.uk](http://nbp.co.uk)

**As frustration over inconsistent pricing practices in construction increases, Northern Building Plastics (NBP) has taken a bold step in its commitment to customers.**

Declaring consistent product pricing across all four of its Super Depots, located in Birtley, Bolton, Hinckley and Leeds, NBP has also revealed a customised and highly competitive pricing approach for each trade sector. "We understand the frustration caused by fluctuating prices in our industry, and that is the driving force behind our guaranteed standard of transparency and consistency across all Northern Building Plastics depots," explains Steve Jones, Sales Director at NBP.

"We know that if customers purchase products at a higher price than what was initially quoted or previously supplied, it has a massive impact on their profit.

"Fluctuation in material costs can be the difference between making money and losing money on a job. By

offering consistent competitive prices across all our Super Depots, we are providing our customers with peace of mind, and they know exactly what to expect when purchasing from any of our depots."

Steve explains: "We've been building highly competitive price lists for different customer types like builders, roofers, commercial contractors, and window installers into our system to offer bespoke pricing packages."

"So, if you walk into NBP and tell me that you're builder or a window installer for example, then we will tailor a pricing package to your account in seconds. That way customers are getting highly competitive pricing on the ranges that are important to their specific trade."

NBP's efforts to address and rectify the issue of inconsistent pricing is just another layer of its overarching goal to maintain a more straightforward, trustful, and efficient procurement process. These include stocking an industry leading range of building products at each Super Depot, plus a delivery fleet of 65 vehicles enabling customers to receive their goods in full and on time every time UK wide. NBP customers can order online any time up to 10pm or from any depot during working hours via phone, email and WhatsApp for free next day delivery direct-to-site.



With a choice of magnetically operated or motorised blinds, our double glazed integral system is suitable for both internal and external use.

Privacy and shading solutions for your home or office.

Totally Cordless and Maintenance Free.

**betweenglassblinds™**  
t. 020 8500 2200 [www.betweenglassblinds.co.uk](http://www.betweenglassblinds.co.uk)

# Home of the famous FENSA Certificate

The industry name you can trust



## FENSA Approved Installers Benefits

Free BFRC Energy Ratings

Win leads from FENSA  
online

Cut costs with a fuel card

Offer finance to your  
customers

10% TradePoint & B&Q  
discount

## Helping you win more work

Join FENSA and we'll connect you to the more than 15,000 searches homeowners make every month when looking for an installer on [www.fensa.org.uk](http://www.fensa.org.uk)



SCAN ME

Join FENSA at  
[fensa.org.uk/join](http://fensa.org.uk/join)

## conservatory outlet boosts its green credentials

[conservatoryoutlet.co.uk](http://conservatoryoutlet.co.uk)

Conservatory Outlet has taken a further leap towards being fully waste-free. The manufacturer of windows, doors and living space products has implemented several additional recycling programmes over the past twelve months.

As a result, the percentage of materials being disposed of and sent to landfill now stands in the single digits – a reduction of over 20%.

Central to this success has been Conservatory Outlet's decision to engage with various recycling specialists to review its waste management processes and make a series of marginal gains

across the business. This has led to more recycling points being installed at its 60,000 sq ft manufacturing facility in Wakefield which allows for a wider range of materials to be collected and recycled.

As the recycling scheme expands, the aim is to be fully waste-free by the end of 2024.

Also, the company has created a dedicated on-site waste management collection point for its customers to use. This allows members of the Conservatory Outlet Premium Retail Network to send waste UPVC and materials back to the company to recycle on their behalf.

Managing Director, Mick Giscombe, said: "It's fantastic to see how as a business we've been cutting down on waste and increasing our recycling statistics year-on-year.

"As part of our ongoing commitment to a more sustainable future, we're taking the lead and ensuring that there is no waste leftover from our manufacturing process.

"We're talking about improving this scheme further and our team is looking at reducing that number to the point where we might even be



recycling at a net gain in the near future. "The focus on recycling is having positive benefits across the business, the environment and our customers.

"Many of our retailer partners talk about how green credentials are becoming more and more important to their customers, so being able to back up their work with our efforts as a sustainable and responsible manufacturer is only a positive thing

## new premium shower and wall panel options in freefoam geo- panel range

[freefoam.com/geopanel](http://freefoam.com/geopanel)

The Geo-panel® range of interior wall panels from Freefoam Building Products has been updated with new premium finishes and marketing materials.

Five new high-quality finishes have been added to the Geo-panel range,

which includes contemporary matt concretes, classic marbles and diamond options. Three are tile finishes: White Gloss, Light Grey Gloss and Azure Gloss, which feature a routed groove for an authentic grouting effect. Meanwhile, Grey Quartz Matt and Grey Azure Matt are stunning full-panel options.

Geo-panel can be fitted to any interior wall to quickly refurbish and restyle bathrooms, kitchens, utility rooms – even home offices. Stockists and installers can now choose from Premium Wide panels, Classic Slim panels, and ceiling panels, plus a variety of high-quality PVC and aluminium trims for a perfect finish.

"We've upgraded the Geo-panel range in response to customer demand," explains Colin St John, Commercial Director for Freefoam. "The new designs are really high-end

and more aspirational - perfect for homeowners who want to renovate or improve their properties in days rather than weeks. It's easier to choose the right panel for different projects too. The new collection is supported with new professionally styled images, a stunning new brochure, swatches and samples, as well as the Visualiser app on [www.freefoam.com/geopanel-visualiser](http://www.freefoam.com/geopanel-visualiser), which has been fully updated."

The tongue-and-groove PVC sections in the Geo-panel system are quick and easy to handle and fit. Designed to slot together in moments, they can be applied over almost any surface, with little preparation – and no grouting – required! With a wipe-clean surface, Geo-panel provides a hygienic and fully waterproof finish that is low-maintenance [wipe-clean!], and durable; guaranteed for 5 years.



## 24 peaks in 24 hours in aid of mind

[conservatoryoutlet.co.uk](http://conservatoryoutlet.co.uk)

After raising over £15,000 for charity last year by completing the National Three Peaks with just minutes to spare, Conservatory Outlet and its Network of Premium Retailers is unveiling its next fundraising effort: The 24 in 24 in '24.

In a bid to up the stakes, figures from Conservatory Outlet and its retail partners will travel to Keswick in June from where they will attempt to scale the Lake District's 24 peaks in just 24 hours.

Led by Conservatory Outlet CEO, Greg Kane, the group will walk over 28 miles and cover over 4,250 metres of elevation – that's more than a marathon and equivalent to climbing Ben Nevis three times!

"After the success of last year's fundraising efforts, we had to go even bigger," Greg begins.

"This will be an incredibly tough challenge for us all. It'll be as much of a mental challenge as a physical one but it's something that we're all looking forward to. We yet again have a fantastic team taking part, with participants coming from across the United Kingdom to help raise money for our charity of choice this year, Mind."

Founded in 1946, Mind is one of the most prominent mental health charities in England and Wales. Mind offers information and advice to people with mental health problems and works tirelessly to raise public awareness and understanding of these issues, as well as campaigning to improve the nation's mental health services.

Speaking about the decision to pick Mind as the group's charity of choice, Greg said: "Mental health issues can affect individuals and families in so many ways. Unfortunately, research shows that one in four people in the UK will experience a mental health problem each year.

"Mind does fantastic work and their work is incredibly important. We trust that you'll support us in our efforts!"

The team will begin their challenge on June 4th going in a circular route before finishing the next day



after climbing Scafell Pike, Helvellyn, Haystacks, Great Gable and 20 other named peaks in the Lake District

Greg ended by adding: "I often say that our Network of Premium Retailers is like a family. Events such as this showcase how strong we are and exactly what we can achieve by working together. There's no doubt that we'll spur each other on and we'll not only complete this monumental challenge but raise a fantastic amount for such a fantastic cause whilst doing so!



hardware

**GLASS BENDING**  
Low Radius Curved Glass Specialists

- Annealed - Laminated
- Single/Double/Triple Glazed Insulated Units
- Minimum Radius 500mm
- Competitive Prices

**HOUNSLOW GLASS** 020 8894 4160  
www.hounslowglass.co.uk sales@hounslowglass.co.uk

insurance

**CPA**  
**Consumer Protection Association**

INSURANCE BACKED GUARANTEES  
DEPOSIT INSURANCE

www.thecpa.co.uk 01462 850062

recycling

**CNC RECYCLING**  
NATIONWIDE UPVC RECYCLING SPECIALISTS

Simple, sustainable recycling of old UPVC windows

Main Plant: CNC Recycling Ltd, 2 Vulcan Street, Middlesbrough, TS2 1PP  
01642 983188 iward@cncrecycling.co.uk upvc-recycling.com

fabricators

HOW DO YOU IMPROVE ON PERFECTION?  
GIVE IT A NAME

**RAYA** (Triple windows) | **AEON** (Double windows) | **AURA** (Aluminium) | **RIVA** (Five composite doors) | **LUNA** (Frameless)

www.ICENIWINDOWS.co.uk

software

**GLASSP**  
Glass Production Software

- Glass & Stock Order Entry
- EDI Direct from your Customers
- Shape & DXF Processing
- Comprehensive Pricing
- Production Planning
- Stock Control & Purchase Orders
- Glass Optimisation
- Delivery Planning & Control
- Links to Cutting Tables and Spacer Benders/Saws
- Production Tracking using Bar Coded Labels on the Glass
- Document Storage & Management
- Credit Control & Accounting
- Reporting & Sales Analysis

01803850460  
sales@highwaysoftware.co.uk

your advert  
here in  
**south east vision**  
for one year!

only **£320** +vat  
(directory double block)

to book call 01675 481920  
or email  
molly@visionpublications.co.uk

**ALCHEMY**  
EXPERTS IN SPECIALIST ALUMINIUM GLAZING

All of the best Aluminium Window and Door Products from the leading Systems

WWW.AAASL.UK  
01922 634009

**SHEERLINE**  
ALUMINIUM WINDOWS AND DOORS

**SGM**  
"The Art of Aluminium"

SGM WINDOW MANUFACTURING  
Honywood Square, Honywood Road, Bealston, Essex, SS14 3RT

STUART BULL, SALES DIRECTOR  
0204 398944  
stuart@sgmwindows.co.uk

**LGR AND GLAZING LTD**  
THE SOUTH EAST DIVISION

- ☑ Supply & Fit
- ☑ On time & efficient
- ☑ Reliable

Korniche Roof Lights | Patent Glazing | Bespoke Glass Roofs | Cortizo OVERSIZED Sliding & BiFold Doors

01737 248 182 - 07730 555 572  
lgrandglazing@hotmail.co.uk

**Seasonmaster**  
Aldershot

manufacturers of  
**Aluminium Bi-Folds and Secondary Glazing**

www.seasonmaster.com

Call 01252 319670  
Fax 01252 341983  
Email sales@seasonmaster.com

supplier

**Here to help you Get a Better Deal**

PVCu | Aluminium | Hardwood | Veranda's  
Lanterns | Aluminium Clad Timber  
Conservatory Roofs | Flat Roof Vents

NATIONWIDE SERVICE  
7.30 - 21.30  
Open 7 Days A Week

For Online Quotes PLUS NEW Door Designer tool visit **www.tpltrade.co.uk**

**Linac**  
**No1 UK Fabricator**

**pearl**  
Window Systems LTD

Suppliers of:  
Casement Windows  
Tilt and Turn Windows  
Timberweld Resurgence Windows  
Bi-Folding Doors  
Patio Doors  
French Doors  
Residential Doors  
Trade GRP Composite Doors  
Solid Core Composite Doors

0800 840277  
sales@pearlwindows.co.uk

**GERDA**  
SUPERBLY ENGINEERED RESIDENTIAL DOORS

**PIONEER**  
WINDOW AND DOORS FOR TRADE

call 01245 362236 email sales@pioneertrc.com

website design

Can your public and trade customers order sealed units & frames online?

**Glassinfo: Website Design & Online Ordering Software**

**SPECIALISTS** FOR CASEMENTS, DOORS, HERITAGE SLIDERS, BI-FOLD DOORS, REVERSIBLES & CONSERVATORIES

INTER - STD  
MECHANICAL PVC (WINDOWS) & VERTICAL SLIDERS  
EUROCELL (BIFOLDS)  
ALUMINIUM PRODUCTS  
BENCHMARK COMPOSITE DOORS  
CRAFTSMAN TIMBER DOORS

**REHAU**  
TOTAL 70C (CHAMFERED)  
TOTAL 70S (SCULPTURED) EDGE  
HERITAGE VERTICAL SLIDERS  
70mm FULLY REVERSIBLES  
RIO FLUSH SASH  
CALIBRE

**INTERFRAME**

Head Office: Exeter, Farnham, Paignton, Plymouth, Poole  
T 01392 824288 T 01329 284224 T 01803 660239 T 01752 230080 T 01202 735522  
F 01803 663030 F 01329 284224 F 01329 233116 F 01803 660209 F 01752 230089 F 01202 744460

your advert here  
in vision  
(midland, northern, south east and south west)

for one year!  
only  
**£1280** +vat  
to book call 01675 481920  
or email  
molly@visionpublications.co.uk

## meeting market demands

[glazpart.com](http://glazpart.com)

For over 40 years Astraseal has been one of the UK's largest PVC-u and aluminium window, door and conservatory manufacturers UK.

To maintain their high reputation and product quality, Astraseal fully appreciate the value of cultivating strong meaningful relationships throughout the glazing supply chain. Their relationship with Glazpart has grown since June 2022, when the Building Regulations (Approved Document F - ventilation) changed.

Being a conscientious company and putting their customers first, it was no surprise, that Astraseal made sure they were ahead of the game and most importantly instantly compliant with the incoming legislation. Since the regulatory changes, their windows and doors have Glazpart's award-winning

Link Vent. The 'Link Vent' range sizes include 5000, 4000 and 2500 EGA. Equivalent Area (EGA) is the measure of the vents' airflow performance. The vents are designed to fully comply with building regulations, Approved document F1 (means of ventilation).

With a clever design that is simple and user-friendly for both opening and closing - the Link Vent's innovative closing action allows the closure plate to be positioned so that it reduces draughts by directing air away from occupants.

The Link Vent 4000 and 5000 closure plate is split to allow for partial (50%) opening and greater ease of opening of the ventilator.

The Link Vent is available in either screw or clip in fixing types - the design eliminates the need for end caps whilst the clip fix design (Pawl's) allows for a fast, easy vent installation.

With smart design, easy fitting, and functionality as well as a huge choice of 1000s of colours and decorative finishes, it is easy to see why Astraseal decided to use the Link Vent for its extensive range of windows and doors.

Colin Stanley, Astraseal Operations Director commented, "We have been ordering from Glazpart for a couple of years, so when the regulations



changed and came into force last year, it was a very easy decision to upgrade our trickle vent solution to the Link Vent range in order to be fully compliant. With our window and doors being installed with the Link Vent, we are applying a solution that works for installers and homeowners. It is a pleasure to be a Glazpartner and work closer with Glazpart, who can always fulfil our requirements."

## ggf at apprenticeship & education event

[ggf.org.uk](http://ggf.org.uk)

The Glass and Glazing Federation (GGF) is pleased to announce that it will be promoting the industry at the Apprenticeship and Education Event in Birmingham on the 25th of April. The event attracts over 6,000 school and college students who are looking to be inspired about their future.

John Mannell, Technical Officer & Training Manager at the GGF, explains why the organisation has decided to exhibit at the event: "It is estimated that the construction industry needs

an additional 50,000 skilled workers, including from the glass, glazing and fenestration industries, to meet the Government's net zero objective, so it is imperative that we play our part in attracting new talent to the sector.

"The Apprenticeship and Education Event will be the first apprenticeship fair we are attending this year, with another following in October and is suitable for school children from the age of 10 years old, right through to college students who are considering the next step on their career path, whether that's further education, training, or employment. The glazing industry has so many different jobs to offer across installation, manufacture, human resources, marketing, and sales, to name just a few, it is important that we are represented at these sorts of events. And if students of school leaving age want more information about jobs available now, they can access the industry Jobs Board that sits on both the GGF and FENSA websites."



John continues: "As the most influential trade association in the industry, with GGF members making up over 60% of the sector's £4 billion annual turnover, we are well positioned to raise awareness and represent the sector. Also, with our own Skilled Pathways Scheme already in place, we have an inside working knowledge of

apprenticeships that we can share with the young people attending apprenticeship fairs.

"We're confident we can play our part in helping the construction sector to meet the Government targets, but we do need to make the most of as many opportunities like this as we can to get there."

## carl f groupco commends secured by design membership

[www.carlfgroupco.co.uk](http://www.carlfgroupco.co.uk)

Leading independent hardware distributor Carl F Groupco has long been a member of Secured by Design. CEO Owen Coop is clear about the importance of the scheme to the business and its customers.

He said: "We have supported the Secured by Design initiative for many years. As a hardware distributor, safety and security components

represent our core product offering and this scheme brings far-reaching benefits that we, and our customers, value."

As well as being a Secured by Design member, Carl F Groupco is also an authorised supplier of Secured by Design products from Cotswold, FUHR, GT Window Products, Hoppe, Kenrick, MACO, Roto, Siegenia and Yale.

Carl F Groupco's Secured by Design membership is just one example of its commitment to initiatives that add value to its customers' businesses. It holds up to £5.5 million of stock, offering a next day delivery service with a target OTIF rate of 98%. The company operates nationally, including to the Scottish Highlands and offshore islands, from distribution centres in Peterborough and Cumbernauld. Alongside its extensive hardware portfolio, it also offers a value-added consultancy service, testing support and works with its customers' fabrication teams and manufacturing partners to scope new hardware solutions and ensure smooth transitions to new ranges.



Owen concluded: "Product quality, first class service and industry knowledge sets us apart as a leading hardware distributor. Our membership of Secured by Design, enhances our ability to uphold these core principles and ensure that product security standards keep pace with emerging crime trends."

# Quality timber windows, doors & conservatories

Storm proof or flush casement windows available

Vertical sliding sash - Traditional or spirals

Conservatories made to measure

Hardwood, softwood and oak

Multi-point security locks

Glazed or unglazed

Stain or paint finish  
*(Multiple choice of colours)*

Competitive prices

Delivery service throughout  
the South East



## Timbercraft Windows

**SPECIALISTS IN MADE TO MEASURE WOOD WINDOWS**

Heckworth Close, off Brunel Way, Severalls Industrial Park, Colchester, Essex CO4 9TB

Telephone: Colchester (01206) 841 433 Fax: (01206) 844 180

tsimpkins@timbercraftwindows.co.uk Mobile 07739 079584

**RETURN ADDRESS**

Vision, Old House Farm,  
Old Farm Lane, Birmingham  
B46 2DL  
Details Incorrect?  
Please let us know  
01675 481920  
press@visionpublications.co.uk

Delivered by

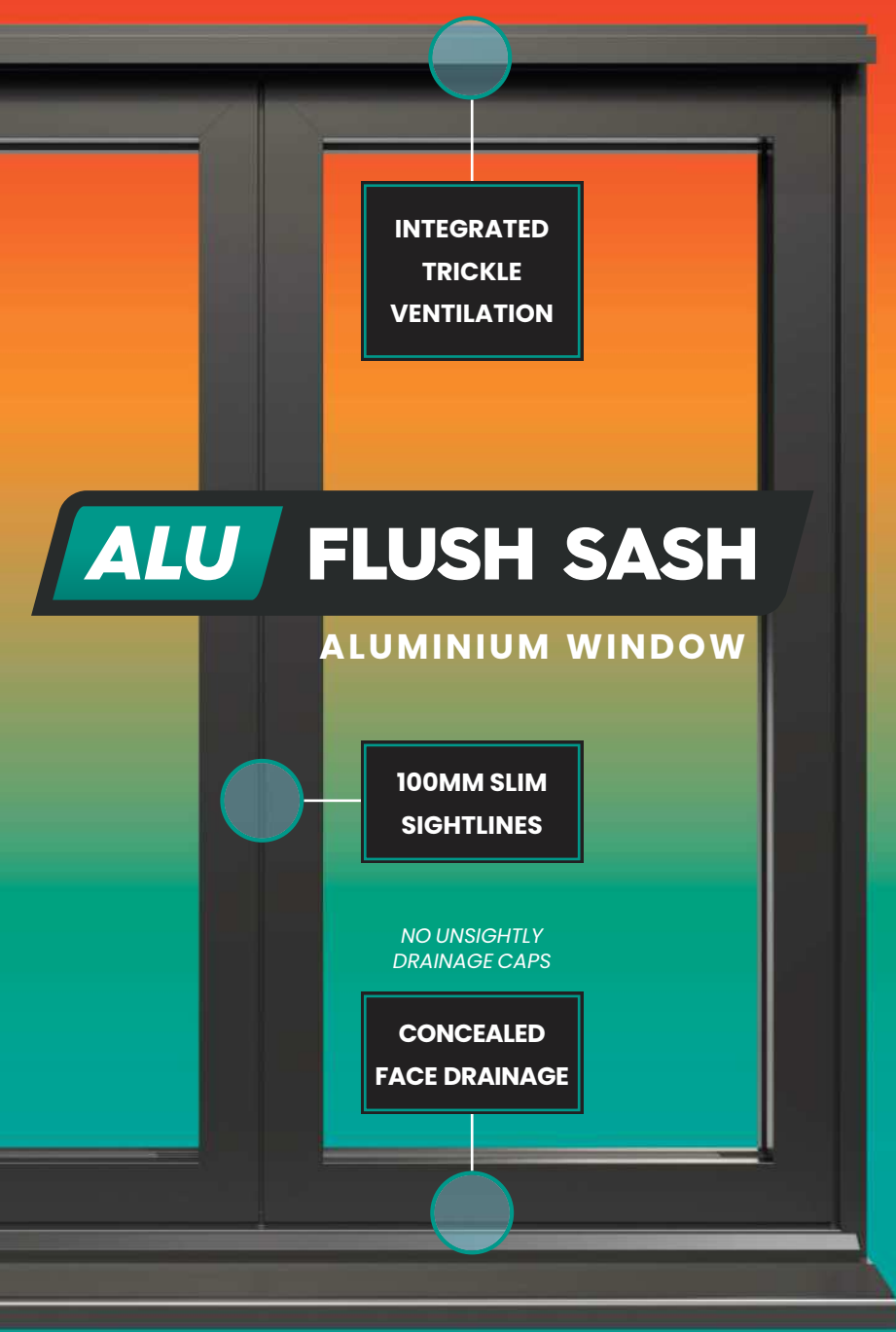

**ALU FLUSH SASH**

ALUMINIUM WINDOW

**STYLISH 70MM INTERNALLY GLAZED FLUSH FIT ALUMINIUM WINDOWS**



**FREE UPGRADE!**

**7 DAY DELIVERY**



**MIDLAND ALUMINIUM**

**01785 287907 | 07538 800203**  
**sales@midlandaluminium.co.uk**